

# SL40 Compact LED Leading Light

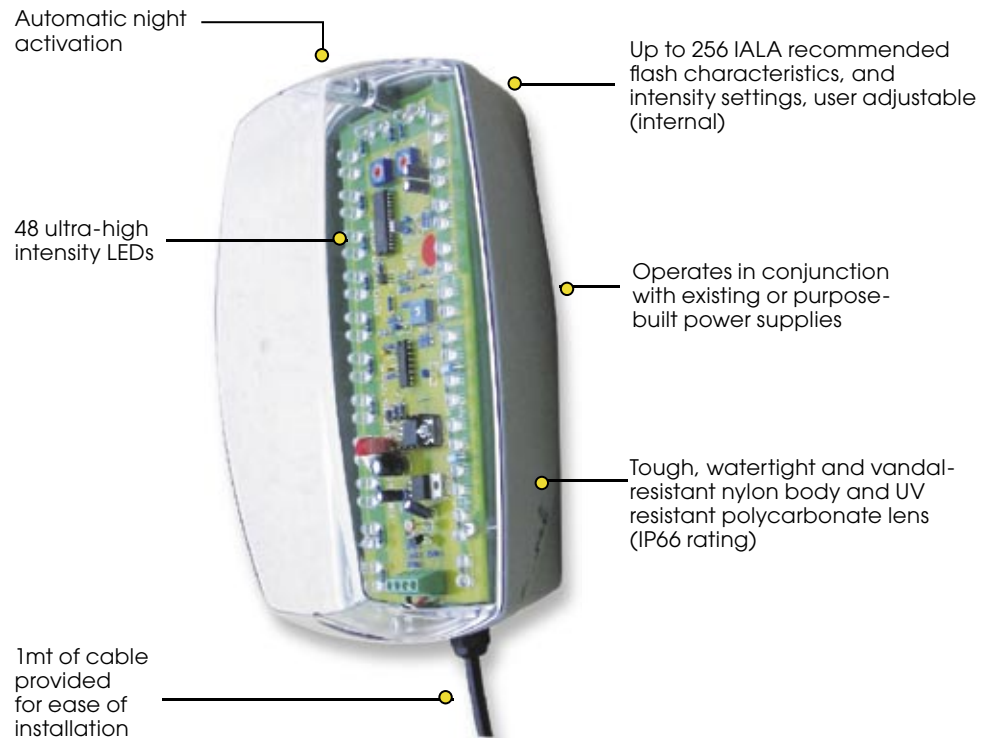

**The Sealite SL40 is a surface mounted directional LED leading light that is a tough, dust and watertight product for situations where outdoor exposure and vandalism can be a problem.**

The SL40 is easily installed, and operates from a 12v input. The unit has an advanced DC/DC converter to supply the LEDs with constant voltage from a variable voltage source.

256 IALA recommended flash characteristics are user-adjustable, and accessed via two rotary switches. In addition, the SL40 has an integrated photodiode for automatic night activation and an onboard trim-pot for intensity adjustment.

The unit has an IP66 rating, being totally dustproof and water-resistant. The body is injection moulded, glass-filled nylon for long life and added strength. The lens is injection moulded, vandal resistant polycarbonate.



# SL40 Compact LED Leading Light

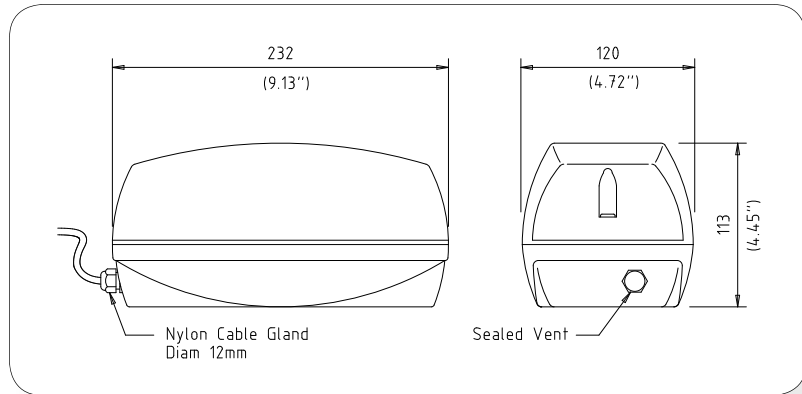

## SPECIFICATIONS •

### Light Characteristics

Light Source	48 ultra-high intensity LEDs
Available Colours	Red, Green, White, Yellow, Blue
Peak Intensity (cd)	>140
Visible Range (nm)	>5.5
Horizontal Output (degrees)	15
Vertical Divergence (degrees)	15
Available Flash Characteristics	Up to 256 IALA recommended (user adjustable)
Intensity Adjustments	User-adjustable
LED Life Expectancy (hours)	100,000

### Electrical Characteristics

Current Draw (mA)	430 (blue, green, white), 510 (red, yellow)
Circuit Protection	Polarity protected
Operating Voltage (v)	12

### Physical Characteristics

Body Material	Injection moulded, glass-filled nylon
Lens Material	UV stabilised injection moulded polycarbonate
Mounting	Provision for bolting from rear
Height (mm/inches)	113 / 4 <sup>1</sup> / <sub>2</sub>
Width (mm/inches)	120 / 4 <sup>3</sup> / <sub>4</sub>
Length	232 / 9 <sup>1</sup> / <sub>8</sub>
Mass (kg/lbs)	1.5 / 3 <sup>1</sup> / <sub>3</sub>
Product Life Expectancy	Up to 12 years

### Certifications

CE	EN61000-6-3:1997, EN61000-6-1:1997
Quality Assurance	ISO9001:2000
Waterproof	IP66

### Intellectual Property

Trademarks

SEALITE® is a registered trademark of Sealite Pty Ltd

### Warranty

3 years

### Options Available

- Power supplies/systems
- Additional cable

CE

• Specifications subject to change or variation without notice

Head Office:  
Sealite Pty Ltd  
AUSTRALIA

Ph. +61 3 5977 6128  
Fax. +61 3 5977 6124  
Internet: [www.sealite.com.au](http://www.sealite.com.au)  
Email: [info@sealite.com.au](mailto:info@sealite.com.au)

USA Customers;  
Sealite USA  
USA (Gilford, NH)

Ph. (603) 524-6066  
Fax. (603) 524-8100  
Internet: [www.sealiteusa.com](http://www.sealiteusa.com)  
Email: [info@sealiteusa.com](mailto:info@sealiteusa.com)

